

# Winlet 915

TECHNICAL SPECIFICATIONS\*

# Winlet

|                                       |                        |                            |                            |
|---------------------------------------|------------------------|----------------------------|----------------------------|
| LIFTING CAPACITY                      | 915 LB                 | TILT FUNCTION              | BACK: 43° FORTH: 98°       |
| MAX LOAD ARM OUT/IN                   | 286 LB / 915 LB        | ROTATION                   | 2 X 180 DEGREES            |
| MAX SIDE MOUNTED LOAD                 | 440 LB                 | SUCTION CUPS               | 4 X 12 IN (14 IN / 16 IN)* |
| TOTAL LENGTH                          | 6 FT 4 IN              | FRONT WHEEL DRIVE          | 1200W                      |
| TOTAL WIDTH                           | 2 FT 9 IN              | 24v AC transaxle           |                            |
| Single mounted tires                  |                        | BATTERIES                  | 2X90 AH                    |
| TOTAL WEIGHT                          | 1,995 LB               | OPERATING HOURS            | 12 HOURS                   |
| LIFTING HEIGHT                        | 10 FT 2 IN             | On fully charged batteries |                            |
| Vertical cups, center of lifting yoke |                        | CHARGING TIME              | 8-10 HOURS                 |
| EXTENSION MIN/MAX                     | 1 FT 5 IN / 4 FT 9 IN  | SUITABLE FOR OUTDOOR USE   | YES                        |
| Front bumper to suction cup           |                        | Water resistant            |                            |
| LIFTING HEIGHT MIN/MAX                | 0 / 3 FT 5 IN          | INTEGRATED LIFTING EYE     | YES                        |
| Horizontal cups down                  |                        | For lifting of the Winlet  |                            |
| LIFTING HEIGHT MIN/MAX                | 8 FT 8 IN / 11 FT 4 IN |                            |                            |
| Horizontal cups up                    |                        |                            |                            |

\*Optional

## WINLET 915 MAX. LOAD/REACH lb.

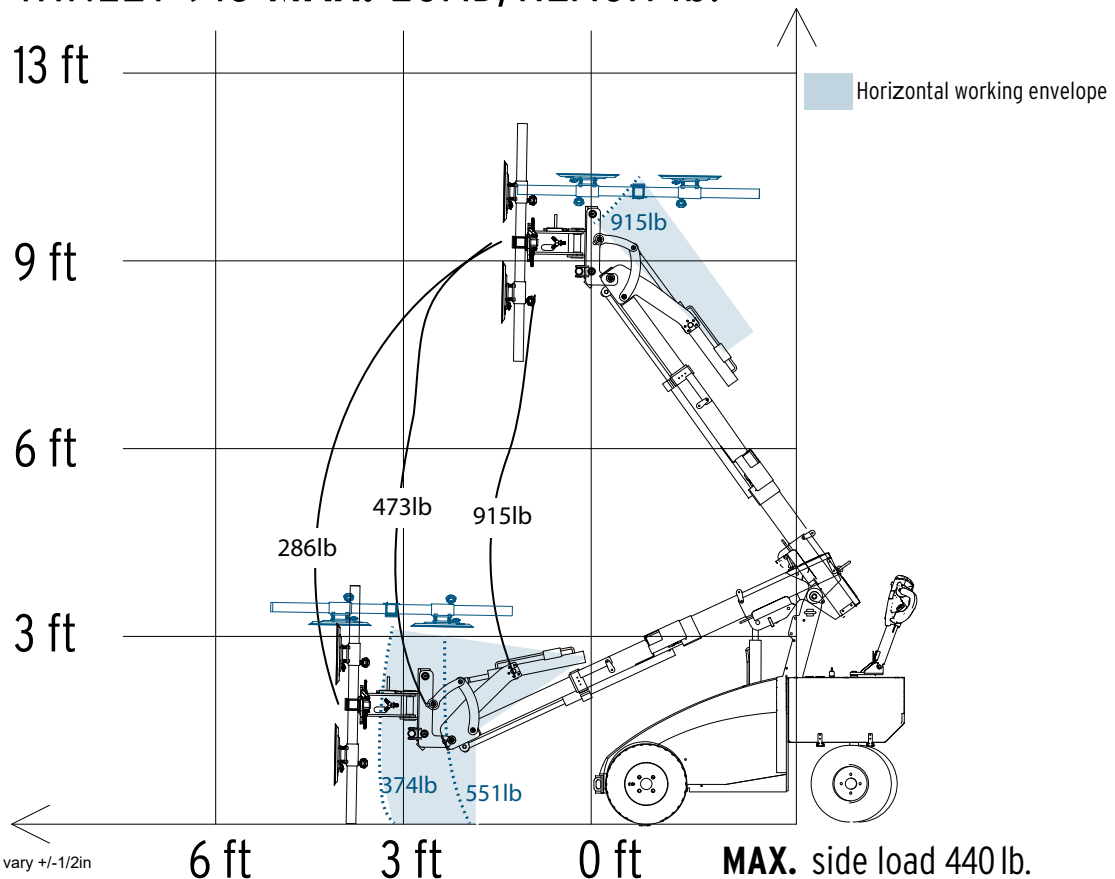

\*The dimensions are indicative and may vary +/-1/2in

[www.winletusa.com](http://www.winletusa.com)

We reserve the right to alterations.

Toll free: 866-358-7088

# Winlet 915

DIMENSIONS\*

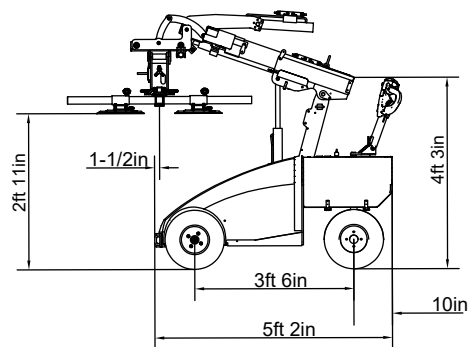
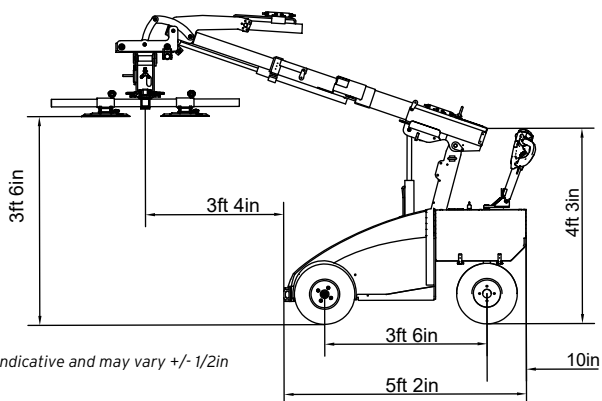
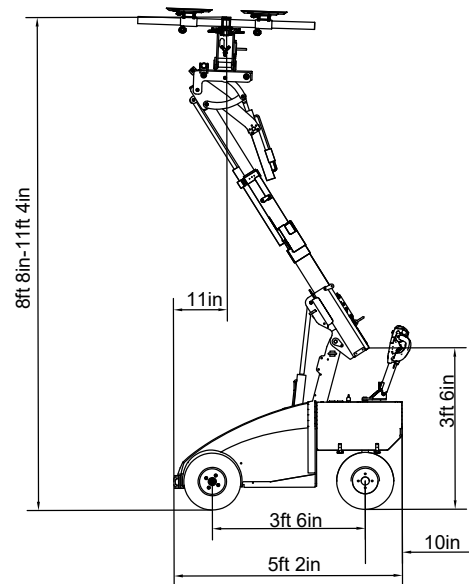
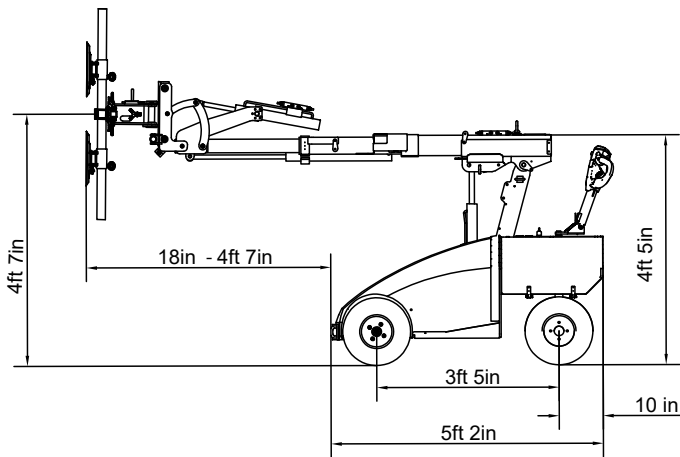
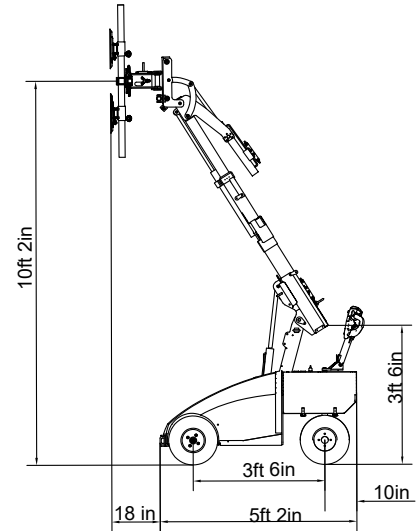
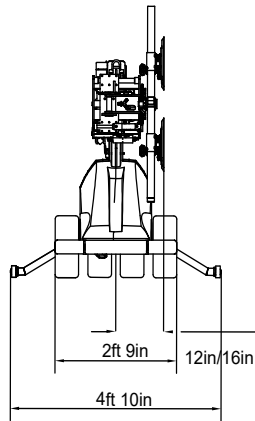
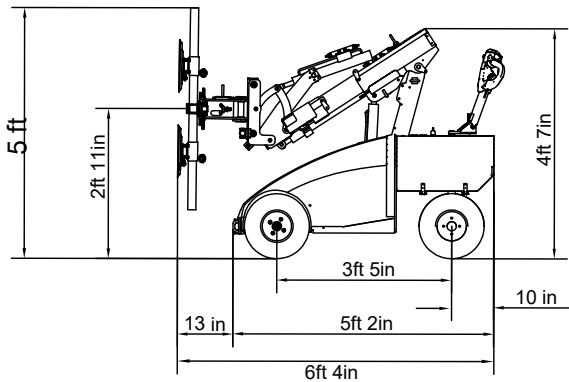

\*The dimensions are indicative and may vary +/- 1/2in

\*

[www.winletusa.com](http://www.winletusa.com)

We reserve the right to alterations.

Toll free: 866-358-7088